



32cd Low-intensity Obstruction Light 12V_{DC} - ICAO Type B. FAA L-810.

CEL-32-12-F - LED Aircraft Warning Light (1st Generation)

Key features

- Extremely reliable - long lifetime
- Very low power consumption
- 12V_{DC} nominal supply voltage
- Intensity 32cd typical
- Stabilised light output
- Lightweight and small-low wind load factor
- Easy to install
- Absolutely no RF-radiations

Benefits

- Long maintenance intervals
- Low energy cost
- Supply power voltage variations do not affect light output
- Very low total lifetime costs
- Low wind load
- Easy to chain
- Comes with five (5) year warranty

Specifications met

- ICAO International Standards and Recommended Practices:
Aerodromes - Annex 14 Volume 1, 5th Edition, July 2009,
Chapter 6: Low-intensity, Type B Fixed Obstacle Light
- FAA Advisory Circular 150/5345-43F 09/12/06 L-810 Light Unit

Optical characteristics

- Intensity better than 32cd
- Colour aviation red
- Horizontal radiation pattern 360°
- Vertical radiation pattern 50°
- LED supply current stabilised by constant current generator
- Light output degradation less than 25% after 100,000hrs of operation

Electrical characteristics

- LEDs in several separate groups
- Nominal operating voltage 12V_{DC}
- Power consumption 5W (0.42A Constant Current)
- Operating voltage range 12 ... 19V_{DC}
- Two-stage over-voltage protection
- Terminal box for 2,5mm² wires
- Easy to chain

Mechanical characteristics

- Yellow painted aluminium body
- Colourless (clear) glass cover
- Terminal box for 1, 5 - 6mm² wires
- Weather protection to IP65
- Operating temperature range -55°C ... +55°C
- Height 235mm, diameter 120mm, weight 0,9kg
- Wind load with CEL-MS-60 mounting kit@ 200km/h less than 40N

Order Code: CEL-32-12-F



CEL-32-12-F



T: +44 (0)20 8540 1034
F: +44 (0)20 8543 3058
E: info@contarnex.com

Contarnex Europe Limited
252 Martin Way,
Morden, Surrey SM4 4AW
United Kingdom



32cd Low-intensity Obstruction Light

12V_{DC} - ICAO Type B. FAA L-810.

CEL-32-12-F - LED Aircraft Warning Light (1st Generation)

CEL-32-12-F is an obstacle light utilising LED technology. The cabling and installation principles are similar to those of conventional obstacle lights, the only exception being the correct polarity required by DC feed.

The recommended polarity is:

- Blue -
- Black +

All connection alternatives can be protected with a 6A or 10A fuse or with a circuit breaker (C curve).

Technical specifications

- Operating voltage: 12V_{DC}
- Power consumption: 5W
- Current consumption: 0,42A
- Two-stage overvoltage protection
- Weather protection: IP65
- Operating temperature range: -55 ... +55°C
- Height: 235mm
- Diameter: 120mm
- Glass cover thickness: 5mm
- Terminal box: yellow powder painted die cast Aluminium
- Weight: 0.9kg

Installation specifications

- Cable gland: PG 16
- Cable diameter: 8 ... 14mm
- Wire diameter: max. 6mm²
- Recommended cable: 4x1.5+1.5 or 2x1.5+1.5mm²
- Fixing hole distance: 100mm
- Fixing screw diameter: max. 5mm
- Fixing base thickness: 5mm

Mounting sets

- CEL-MS-60: Mounting onto Ø 30 ... 60mm pipes
- CEL-MS-1 00: Mounting onto Ø 60 ... 100mm pipes
- U-bolts and hex nuts M8: acid-proof steel
- Mounting plate: black anodised aluminium

Options

- CEL-MS-60 Mounting kit
- CEL-MS-1 00 Mounting kit
- CEL-PCFL -DC1 -TB Photocell
- CEL-CSW Photocell/Change Switch Unit

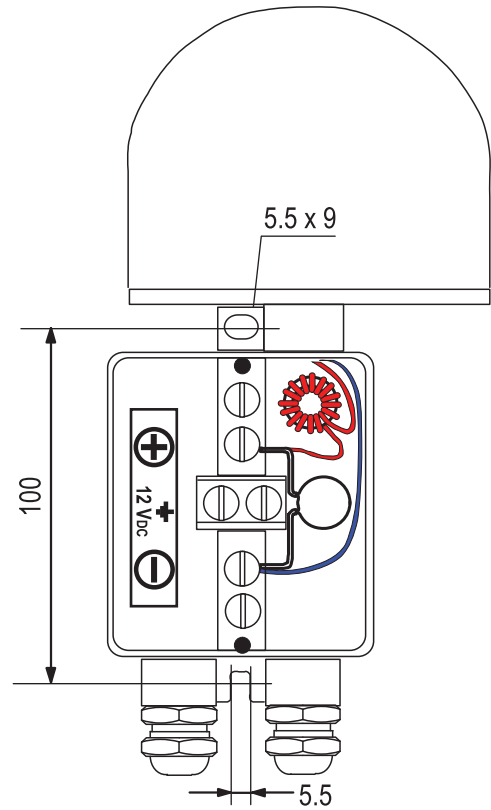

CEL-32-12-F terminal box

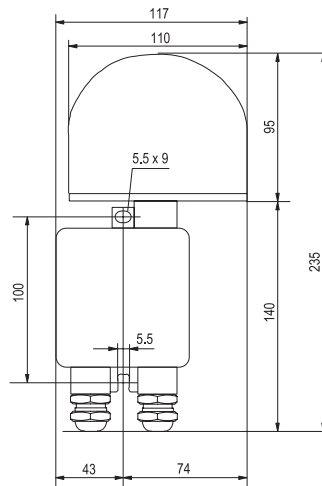

CEL-32-12-F dimensions

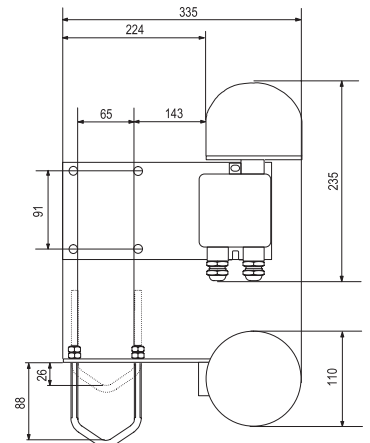

CEL-MS-60 Mounting Set dimensions



32cd Low-intensity Obstruction Light

12V_{DC} - ICAO Type B. FAA L-810.

CEL-32-12-F - LED Aircraft Warning Light (1st Generation)

There are several types of mounting sets available as option.

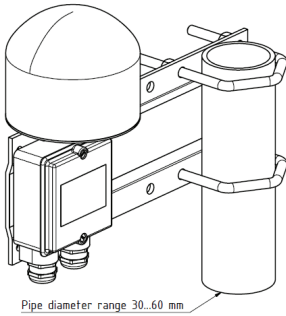

Pipe diameter range 30...60 mm

There are several types of mounting sets available as option.
For example:

CEL-MS-60

Mounting set with extension plate for 30-60 mm vertical pipe installation

Mounting set include:

- 2 pcs 65 mm, M8 U-bolt, 8 pcs M8 hex nut
- 2 pcs M5x30 bolt, 2 pcs M5 nyloc hex nut, 2 pcs washer
- 1 pcs extension plate

Extension plate marine grade anodised aluminium, other parts AISI 316 acid proof steel

More detailed mechanical data: MS-60 datasheet

Order Code: CEL-MS-60

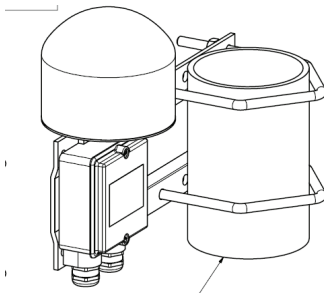

Pipe diameter range 60...100 mm

CEL-MS-100

Mounting set with extension plate for 60-100 mm vertical pipe installation

Mounting set include:

- 2 pcs 105 mm, M8 U-bolt, 8 pcs M8 hex nut
- 2 pcs M5x30 bolt, 2 pcs M5 nyloc hex nut, 2 pcs washer
- 1 pcs extension plate

Extension plate marine grade anodised aluminium, other parts AISI 316 acid proof steel

More detailed mechanical data: MS-100 datasheet

Order Code: CEL-MS-100

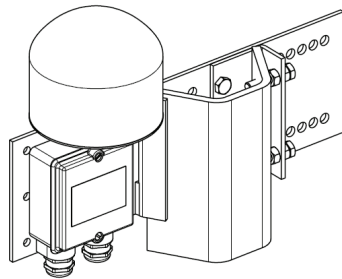

CEL-MS-TRA-LVU

Mounting set for Land V -shape profiles

Mounting set include:

- 1 set accessories for light unit fitting to plate
- 1 pcs extension plate with adjusting plate and accessories

Extension plate hot dip galvanized steel, other parts AISI 316 acid proof steel

More detailed mechanical data: MS-TRA-LVU datasheet

Order Code: CEL-MS-TRA-LVU (with galvanized extension plate)

CEL-MS-TRA-LVA (with AISI 316 extension plate)